



Control Panel (CP375, CP600)

This unit provides direct button selection of the available steering control modes. It is configured for each system installation. Mode selection is located at every steering station as required by Classification Societies.

- Selected mode of steering is illuminated
- Control Panel face is backlit and includes a built-in dimmer control.
- Fault light and audible alarm are built in
- Black Lexan face panels are:
 - * 3 in. (76mm) wide by 6 in. (152mm) high, or
 - * 3 in. (76mm) wide by 3 3/4 in. (95mm) high
- Panels are water resistant from front.
- Selection panels can also be supplied by others for integration into an integrated bridge

Jastram Digital Control System Summary

The key features of the Jastram Digital Steering Control System are:

- Optional VDR (Vessel Data Recorder) Interface
- Autopilot, Joystick or DP systems are easily interfaced
- Custom configurations can be easily accommodated including:
 - * Twin independent systems for DP & Joystick compliance
 - * Duplicate Full Follow-up systems for redundancy
 - * Proportional hydraulics
- The RFU 2000 is the suggested feedback for the Digital system
- All Jastram Digital and Analog Input Devices work with the Digital Steering system
- DNV Type Approved for Classification of Ships, High Speed & Light Craft and DNV Offshore Standards
- GL Approval Certificate Guidelines for the Performance of Type Approvals Part 2, Edition 2003, IEC 60945 (2002)

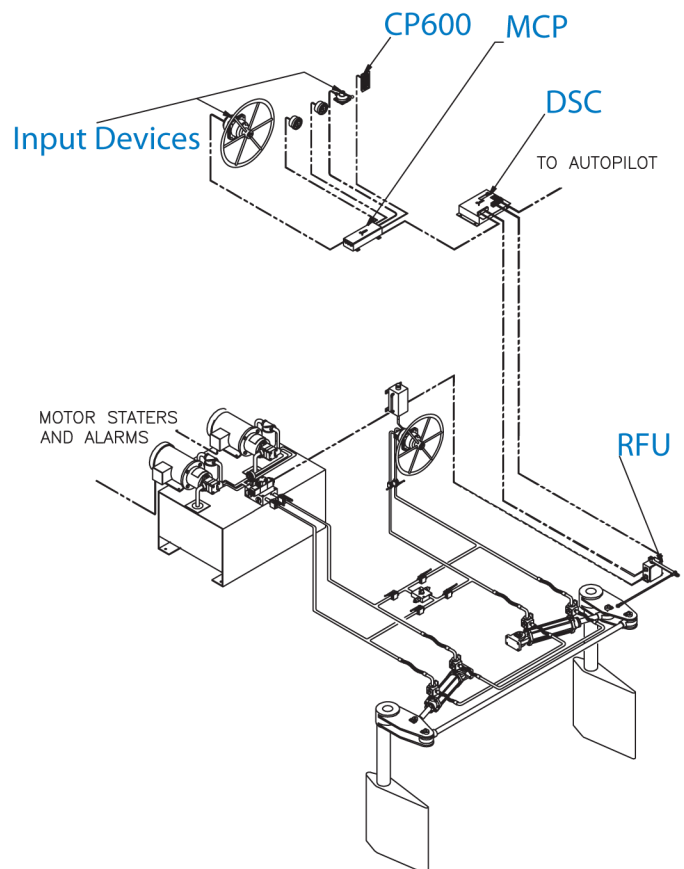

Data is subject to change without notice.

